

Information-Seeking Chat: Dialogue Management by Topic-Structure

Manfred Stede
David Schlangen

Department of Linguistics
University of Potsdam
{stede|das}@ling.uni-potsdam.de

Overview

- What is "information-seeking chat"?
 - informal definition; a paradigm example
- Corpus Study
 - Dialogue Acts for ISC
- Our Approach: Dialogue Management by topic-structure
 - the idea
 - the "topic-structure" (ontology) in our prototype example
- Evaluation
- Sketch of other modules
- Conclusions & Further Work

What's *information-seeking chat*?

- informal definition:

"Mixed-initiative dialogue between an expert and a user, focussed on exploring a complex topic (and not e.g. on transactions)"

What's *information-seeking chat*?

- informal definition:

"Mixed-initiative dialogue between an expert and a user, focussed on exploring a complex topic (and not e.g. on transactions)"

- example setting:

"Imagine you will be in Potsdam for a conference, and wonder whether you should stay for the weekend afterwards. You want to ask a tourist office person about what's on offer that would make a stay worthwhile."

What's *information-seeking chat*?

- other settings:

- information about companies, institutions, etc.
- simple inquiry-based teaching/learning?

What's *information-seeking chat*?

- differences & sim. to other dial-genres:

- *travel information*:
 - ISC less easily modelled as template filling,
 - ISC less driven by simple "low-level" goal ("find me flight to xyz on zyk..")

What's information-seeking chat?

- differences & sim. to other dial-genres:
 - *travel information*:
 - ISC less easily modelled as template filling,
 - ISC less driven by simple "low-level" goal ("find me flight to xyz on zyk..")
 - *tutorial dialogue*:
 - similar: expert w/ knowledge, wants to tell something
 - diff: no corrections, no socratic approach needed

What's information-seeking chat?

- differences & sim. to other dial-genres:
 - *travel information*:
 - ISC less easily modelled as template filling,
 - ISC less driven by simple "low-level" goal ("find me flight to xyz on zyk..")
 - *tutorial dialogue*:
 - similar: expert w/ knowledge, wants to tell something
 - diff: no corrections, no socratic approach needed
 - *collaborative planning* (a la TRAINS):
 - ISC a lot simpler: world is closed, static, no complicated reasoning required, ...

What's information-seeking chat?

- differences & sim. to other dial-genres:
 - *travel information*:
 - ISC less easily modelled as template filling,
 - ISC less driven by simple "low-level" goal ("find me flight to xyz on zyk..")
 - *tutorial dialogue*:
 - similar: expert w/ knowledge, wants to tell something
 - diff: no corrections, no socratic approach needed
 - *collaborative planning* (a la TRAINS):
 - ISC a lot simpler: world is closed, static, no complicated reasoning required, ...
 - *diff. to all these kinds*: no objective criteria for task-completion

Corpus Study

- collected 13 dialogues via chat-tool
- scenario: "Imagine you will be in Potsdam for a conference, and wonder whether you should stay for the weekend afterwards. You want to ask a tourist office person about what's on offer that would make a stay worthwhile."
- users were not familiar w/ Potsdam
- average length of dials: 17 turns

An Example Dialogue

1 E Hello. This is PTI. How may I help you?
2 U Well, I'd like to know whether a weekend in Potsdam is worthwhile.
3 E A weekend in Potsdam is always worth your while; there are lots of things to do.
4 U Like what?
5 E For example, you can make a boat trip, or a sightseeing tour. Always popular with tourists is Park Sanssouci.
6 U Is all of this in the inner city? Can you walk to these things, or do you have to use some kind of transport?
7 E It's probably best to take the bus. SansS. isn't really in the center. ...
8 U Sounds good. Are there any reasonably priced hotels near the station?

An Example Dialogue

...
12 U Are there things to do for kids as well?
13 E A popular attraction for kids is the "Filmpark" in Babelsberg.
14 U How far away is that? Which tramline?
15 E It's only two stops from the station. ...
16 U Only two stops, great. Is the entrance fee very high?
17 E Entrance is €17 for adults and €10 for children.
18 U Not exactly cheap. What's on offer there?
19 E You can visit the UFA-filmstudio, or you can enjoy the theme park attractions such as rollercoasters and stuff.
20 U Sounds good. I think I'll stay in P then.

Observations

Pattern of dialogue moves:

- users ask for general inf. about topic
- expert gives inf., offers alternative ways of exploring topic further
- user explores topic (attributes, or sub-topics); or user restarts pattern w/ diff. topic

Observations

Pattern of dialogue moves:

- users ask for general inf. about topic
- expert gives inf., offers alternative ways of exploring topic further
- user explores topic (attributes, or sub-topics); or user restarts pattern w/ diff. topic

```
3 E A weekend in Potsdam is always worth your while;
there are lots of things to do.
4 U Like what?
5 E For example, you can make a boat trip, or a
sightseeing tour. Always popular with tourists is
Park Sanssouci.
6 U Is all of this in the inner city? Can you walk to
these things, or do you have to use some kind of
transport?
7 E It's probably best to take the bus. SansS. isn't
really in the center. ...
8 U Sounds good. Are there any reasonably priced hotels
near the station?
```

Observations

Pattern of dialogue moves:

- users ask for general inf. about topic
- expert gives inf., offers alternative ways of exploring topic further
- user explores topic (attributes, or sub-topics); or user restarts pattern w/ diff. topic

```
12 U Are there things to do for kids as well?
13 E A popular attraction for kids is the "Filmpark" in
Babelsberg.
14 U How far away is that? Which tramline?
15 E It's only two stops from the station. ...
16 U Only two stops, great. Is the entrance fee very high?
17 E Entrance is €17 for adults and €10 for children.
18 U Not exactly cheap. What's on offer there?
19 E You can visit the UFA-filmstudio, or you can enjoy
the theme park attractions such as rollercoasters and
stuff.
20 U Sounds good. I think I'll stay in P then.
```

Observations

Pattern of dialogue moves:

- users ask for general inf. about topic
- expert gives inf., offers alternative ways of exploring topic further
- user explores topic (attributes, or sub-topics); or user restarts pattern w/ diff. topic

Initiative:

- mostly from user! (89% of all questions; where 35% of all turns are questions)

Preliminary Conclusions

- too unrestricted for finite-state DM
- structured knowledge about domain is needed to guide dialogue

Dialogue Acts for ISC

- ask-more
 - ask-more-general
 - ask-more-specific {<T>}
 - ask-more-attribute
- reply
 - reply-pos
 - reply-neg
- tell
 - tell-topic-general
 - tell-spec-attribute
- rule-out-topic
- switch-topic <T>
- noncommittal
- digression
- bye, opening, closing, help, garbage

Dialogue Acts for ISC

- ask-more
 - ask-more-general
 - ask-more-specific {<T>}
 - ask-more-attribute
- reply
 - reply-pos
 - reply-neg
- tell
 - tell-topic-general
 - tell-spec-attribute
- rule-out-topic
- switch-topic <T>
- noncommittal
- digression
- bye, opening, closing, help, garbage

} *Elab_q*

} *Elab*

Dialogue Acts for ISC

- two naive coders marked up corpus:
 - 98% coverage
 - .81 Kappa

Our Approach

- Reduce Dialogue Management to controlling exploration of a *topic map*...
- ... guided by *weights* that represent discourse history.

A Topic Map

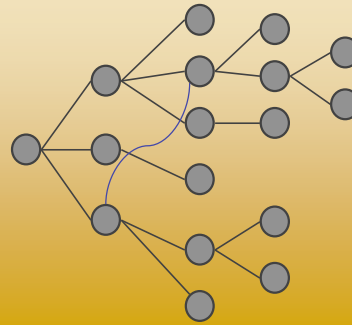

Initial state: *a priori* prominence

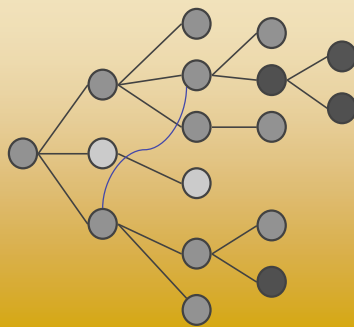

System gives info about **node**

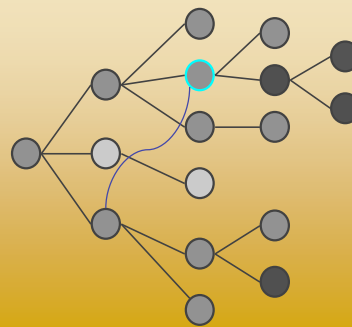

The weight-update mechanism

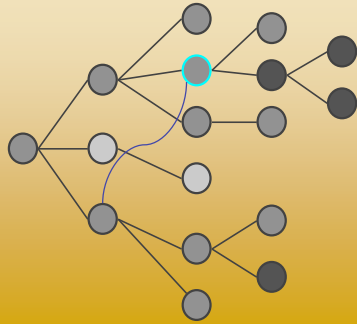

The weight-update mechanism

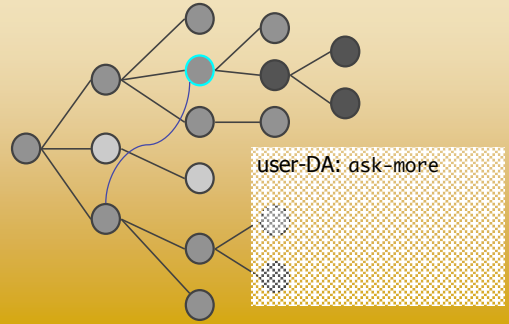

The weight-update mechanism

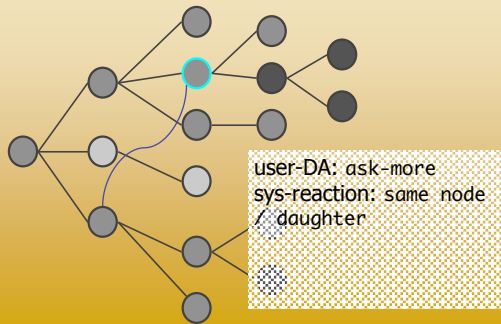

The weight-update mechanism

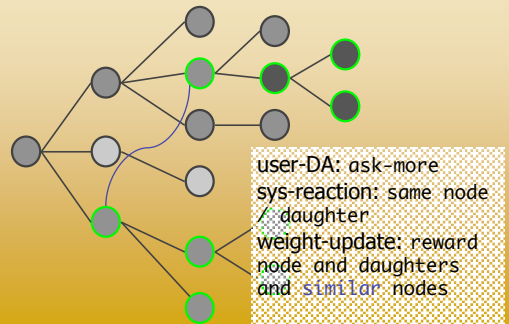

The weight-update mechanism

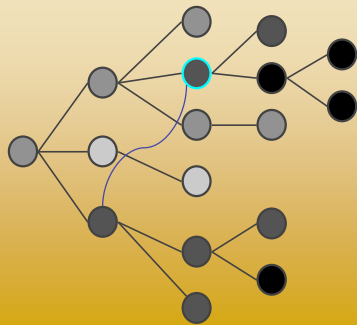

The weight-update mechanism

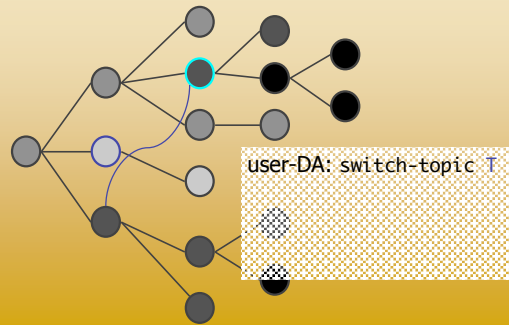

The weight-update mechanism

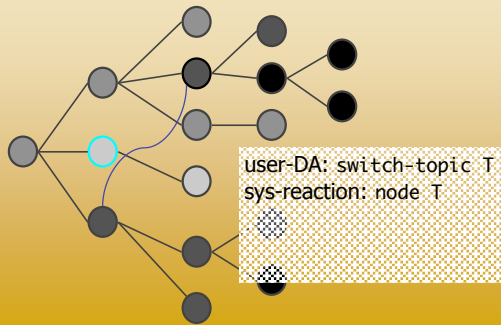

The weight-update mechanism

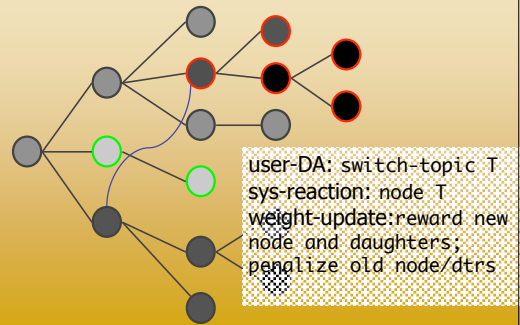

The weight-update mechanism

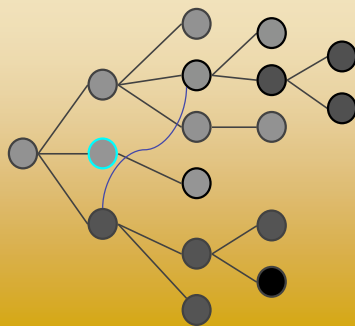

The weight-update mechanism

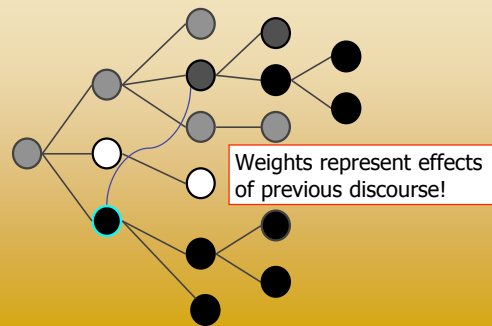

The Prototype

- implemented in LISP / LOOM, i.e. knowledge is represented in Description Logic
 - declarative specification of domain knowledge, deductive database capabilities
 - object-oriented programming for weight-update
- written input
(actually, input is DA)

The City-Tourism Ontology

city-topic

The City-Tourism Ontology

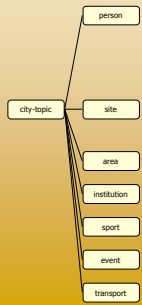

The City-Tourism Ontology

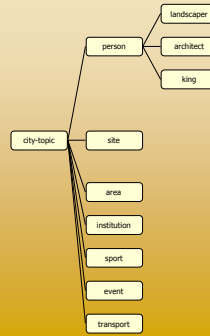

The City-Tourism Ontology

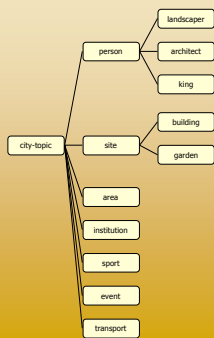

The City-Tourism Ontology

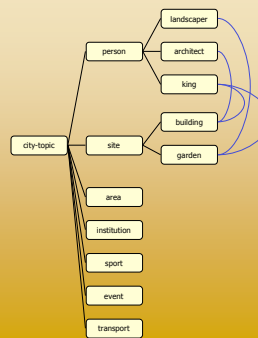

The City-Tourism Ontology

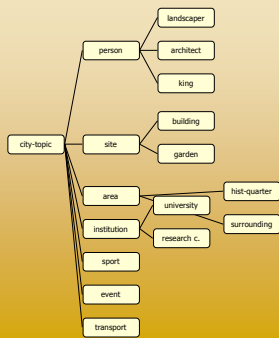

The City-Tourism Ontology

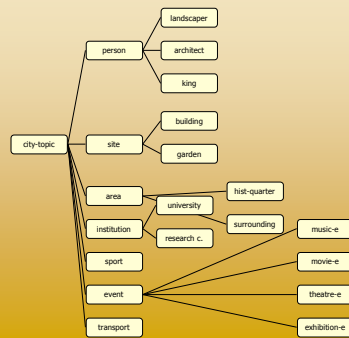

The City-Tourism Ontology

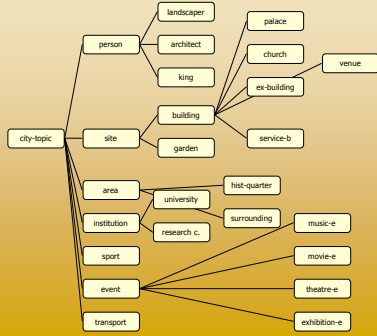

The City-Tourism Ontology

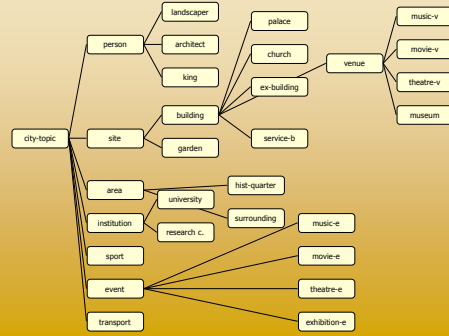

The City-Tourism Ontology

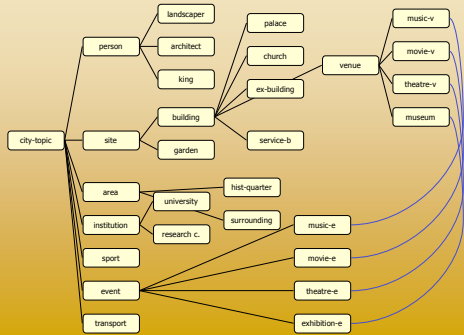

The City-Tourism Ontology



The City-Tourism Ontology



The City-Tourism Ontology



Ontology - Summary

- Concept nodes representing topics
- associated "slots":
 - person has birthyear, place, etc.
 - site has location, building has address, etc.
- relations between concepts:
 - buildings can have architects, can be commissioned by kings, etc.
- properties get inherited by daughters of node (multiple inheritance possible)

The Potsdam Ontology

- so far, only *concepts* (valid for all cities)
 - T-Box
- we need *instances* representing Potsdam
 - A-Box
- (at the moment, we also need *utterances*)

The Potsdam Ontology (excerpt)

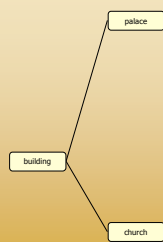

The Potsdam Ontology (excerpt)

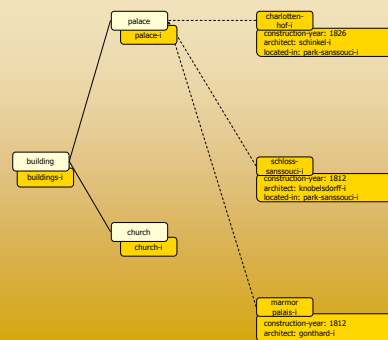

The Potsdam Ontology (excerpt)

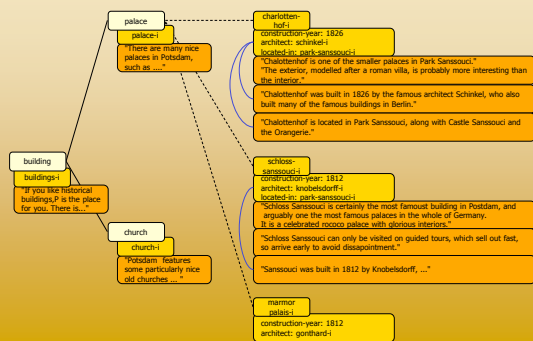

The Potsdam Ontology (excerpt)

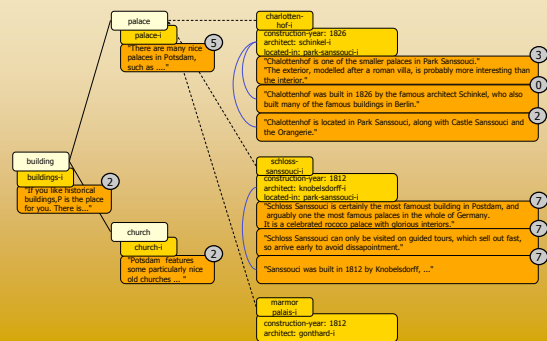

An Example

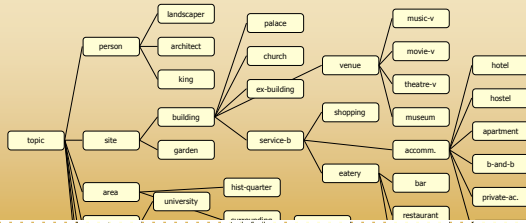

S: This is the Potsdam Tourism Information System. How may I help you?

U: Well, I'd like to know more about what's on offer in Potsdam.
switch-topic potsdam

>

An Example

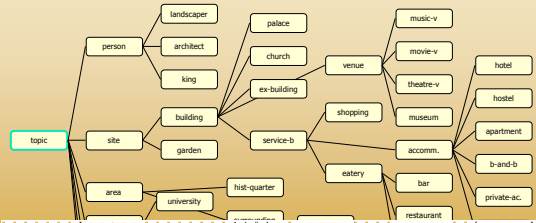

U: Well, I'd like to know more about what's on offer in Potsdam.
switch-topic potsdam

>

An Example

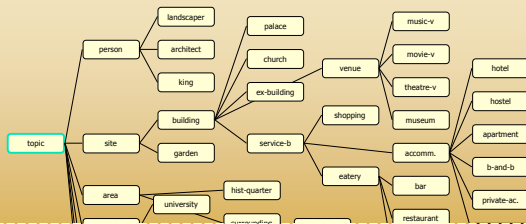

U: Well, I'd like to know more about what's on offer in Potsdam.
switch-topic potsdam

S: "Potsdam is very famous for its nice palaces, the beautiful parks and the nicely preserved old town. However, there are also many other interesting things, like museums, a theme park, or concert venues."

U: Great, I like museums. What's on offer there?
ask-specific <museums>

>

An Example

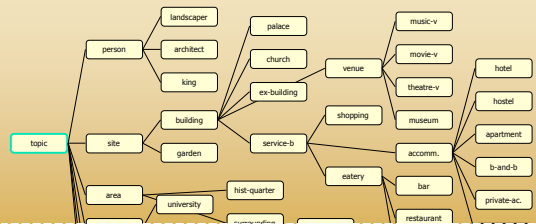

S: "Potsdam is very famous for its nice palaces, the beautiful parks and the nicely preserved old town. However, there are also many other interesting things, like museums, a theme park, or concert venues."

U: Great, I like museums. What's on offer there?
ask-specific <museums>

>

An Example

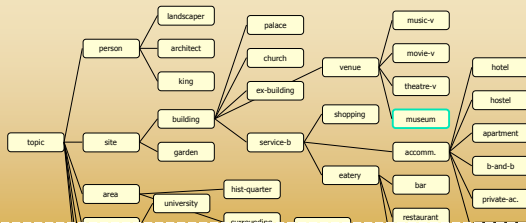

U: Great, I like museums. What's on offer there?
ask-specific <museums>

>

An Example

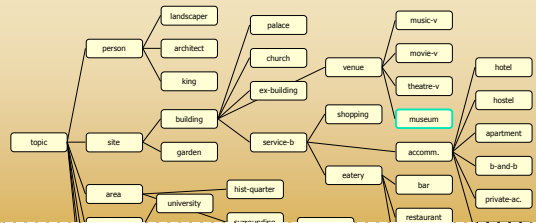

U: Great, I like museums. What's on offer there?
ask-specific <museums>

S: There are several museums in Potsdam that can be recommended (and not only if the weather is bad), for example the Filmmuseum, or the museum for Brandenburgian and Prussian history, or, for kids, the Kindertagesstaettenmuseum.

An Example

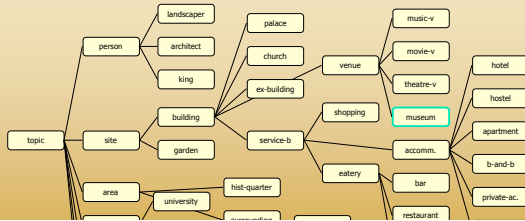

S: There are several museums in Potsdam that can be recommended (and not only if the weather is bad), for example the Filmmuseum, or the museum for Brandenburgian and Prussian history, or, for kids, the Kindertagesstättenmuseum.

U: *Filmmuseum, that sounds interesting. What's that?*
ask-specific <film-museum>

An Example

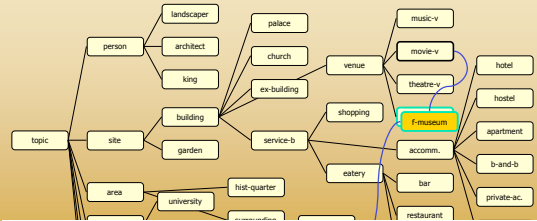

U: *Filmmuseum, that sounds interesting. What's that?*
ask-specific <film-museum>

Preliminary Evaluation ***new***

- Wizard of Oz study: wizard maps user input to Dialogue Acts, reply comes from system.
- again run via chat-tool
- base-line: version that uses same content, but no initiative, spits out all content at node.
- users fill out questionnaire (Likert-scale)

Preliminary Evaluation

- Wizard of Oz study: wizard maps user input to Dialogue Acts, reply comes from system.
- again run via chat-tool
- base-line: version that uses same content, but no initiative, spits out all content at node.
- users fill out questionnaire (Likert-scale)
- good news: better than baseline

Preliminary Evaluation

- Wizard of Oz study: wizard maps user input to Dialogue Acts, reply comes from system.
- again run via chat-tool
- base-line: version that uses same content, but no initiative, spits out all content at node.
- users fill out questionnaire (Likert-scale)
- good news: better than baseline
- bad news: still pretty bad
 - useability: 3.1 (bl: 2.2)
 - use again: 3.9 (bl: 3.1)
 - prefer human: 3 (bl: 4.3)
 - found inf.: 3.8 (bl: 3.6)

What about -

- clarification subdialogues?
 - don't do them at the moment! (will of course need them when we do DA recognition!)
- collecting specific information like travel dates?
 - don't do that at the moment!
- idea: pass over control for such subdialogues to different Dialogue Manager!

Related Work

- Construct Algebra (Abella & Gorin, 1999)
- WAXHOLM system (Carlson & Hunnicutt, 1996)
- SMARTCOM system (Gurevych et al., 2003)
- Linguamatics system (Millward & Beveridge, last Monday)
- DL for Adventure Game (Koller et al., forth.)

Relation to ISU-based systems

- instantiation of ISU approach for specific dialogue genre:
 - we do have IS, and update rules triggered by DAs
 - our IS is both simpler and more complicated:
 - no distinction private / public
 - no QUD, but whole domain knowledge
 - cumulative dialogue history
- no (explicit) plans (implicit plan: follow user's interests, visit prominent nodes)
- domain knowledge would be needed anyway!

Sketch of other modules

- DA-recognition:
 - uses patterns for DAs, keywords from ontology for parameters (topics to jump to, attributes to talk about)
- Generation:
 - mixture of canned text (for "promotional" bits) and template based generation (for attributes like "entrance fee", etc.)
- Speech Input??
 - compile grammars out of patterns and keywords?

Conclusions

What we have done:

- presented study of dialogue genre "Information Seeking Chat"
- sketched approach to modelling dialogue flow, & an implementation of it
 - topic-structure (ontology) & weights
 - "respond & elaborate"
 - declarative representation of domain knowledge;
 - portable to other...
 - ... cities: new instances / utterances
 - ... domains: new ontology
 - separate domain knowledge & dialogue knowledge
- (interested you in Potsdam?)

Further Work

What we would like to / will do:

- (see other modules)
- more types of utterances: besides *facts* also highlights, motivators, etc..
- interfaces to other DMs -- dynamic loading of DMs
- multimodality: automatically load webpages, show pictures, etc.
- *learn* information, eg. similar-topic. ("users who were interested in ... also liked ...")

The End

Thank you!

Acknowledgements:
Thanks to Trevor Austin,
Tatjana Lucht and Antje Machon
for help w/ coding and evaluation.

Dialogue Acts for ISC

1	E	Hello. This is PTI. How may I help you?	opening
2	U	Well, I'd like to know whether a weekend in Potsdam is worthwhile.	switch-topic
3	E	A weekend in Potsdam is always worth your while; there are lots of things to do.	tell-topic-general
4	U	Like what?	ask-more-spc
5	E	For example, you can make a boat trip, or a sightseeing tour. Always popular with tourists is Park Sanssouci.	tell-topic-general
6	U	Is all of this in the inner city? Can you walk to these things, or do you have to use some kind of transport?	ask-spc-attr.
7	E	It's probably best to take the bus. SansS. isn't really in the center. ...	tell-spc-attr
8	U	Sounds good. Are there any reasonably priced hotels near the station?	switch-topic

A Topic Map

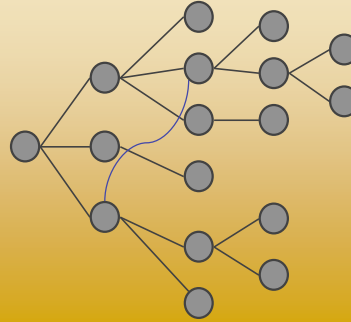

Initial state: *a priori* prominence

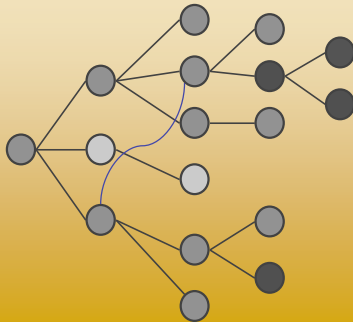

System gives info about node

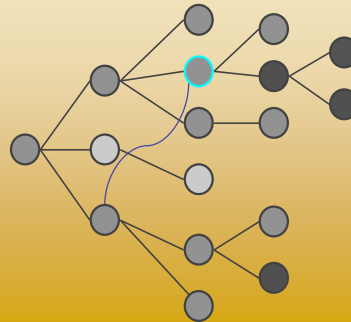

The weight-update mechanism

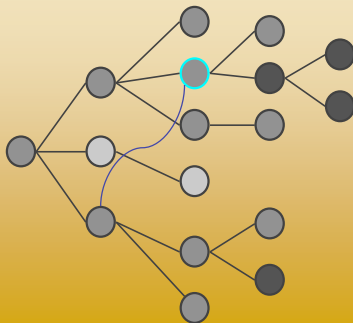

The weight-update mechanism

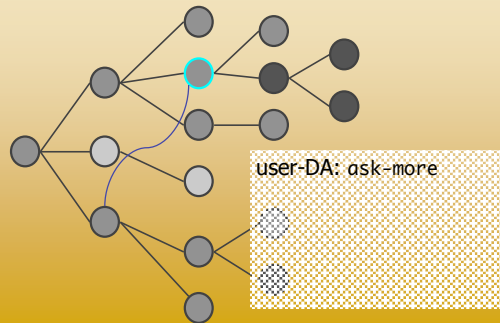

The weight-update mechanism

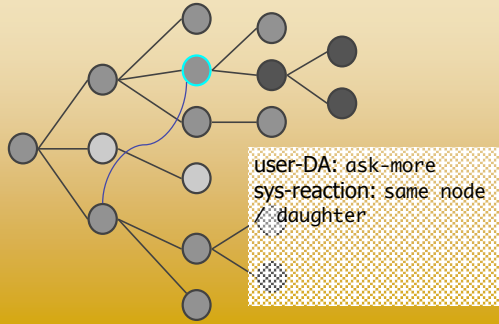

The weight-update mechanism

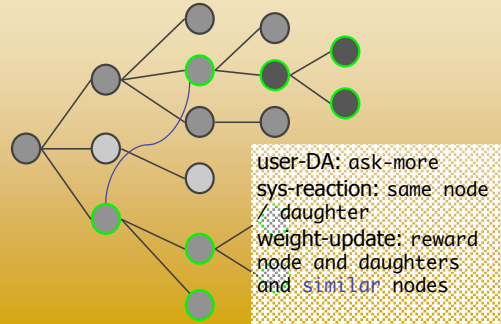

The weight-update mechanism

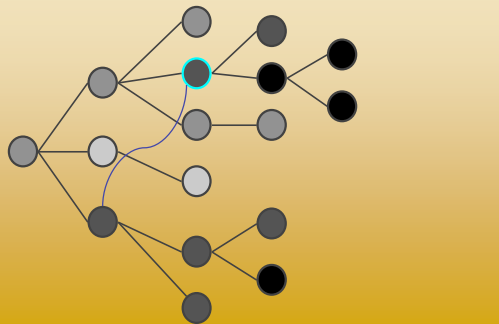

The weight-update mechanism

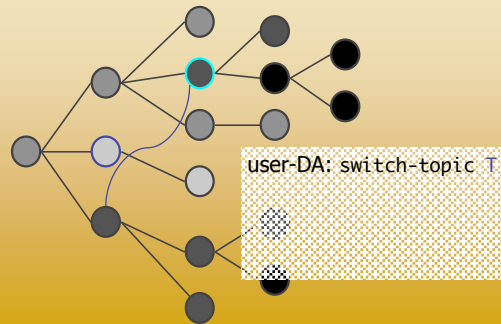

The weight-update mechanism

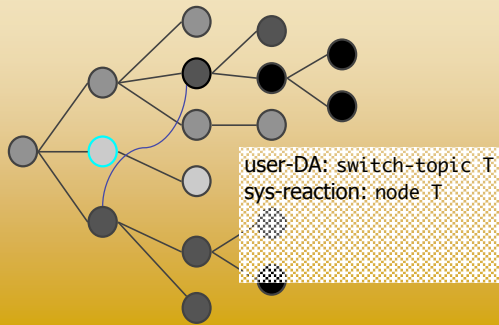

The weight-update mechanism

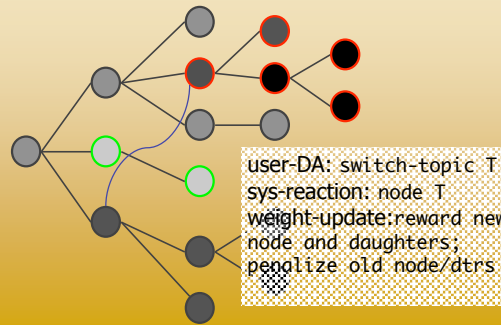

The weight-update mechanism

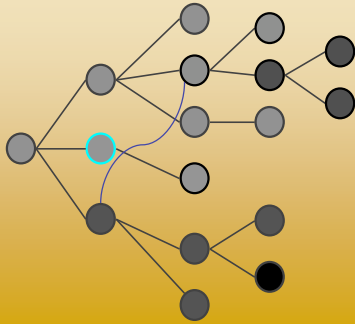

The weight-update mechanism

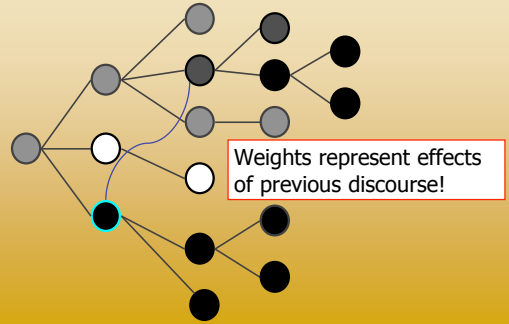

The weight-update mechanism

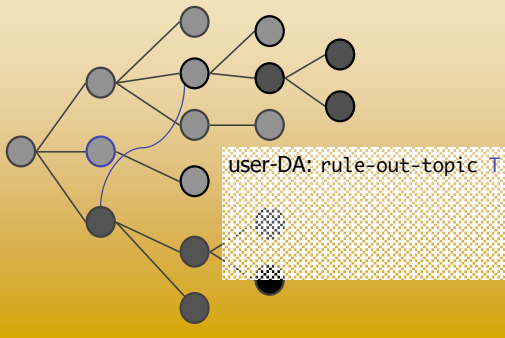

The weight-update mechanism

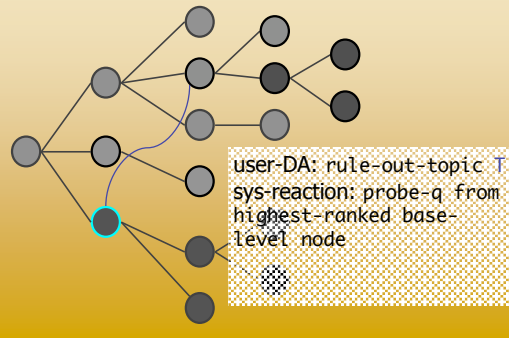

The weight-update mechanism

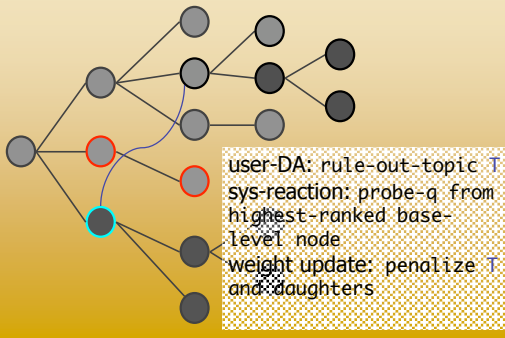

The weight-update mechanism

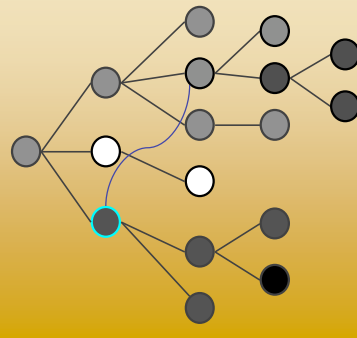

The weight-update mechanism

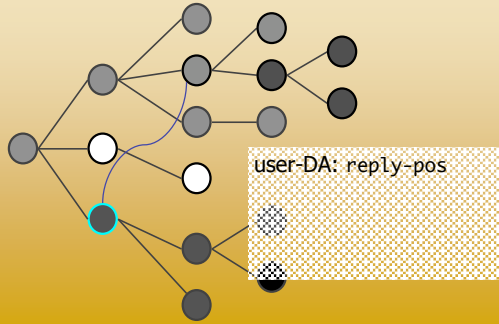

The weight-update mechanism

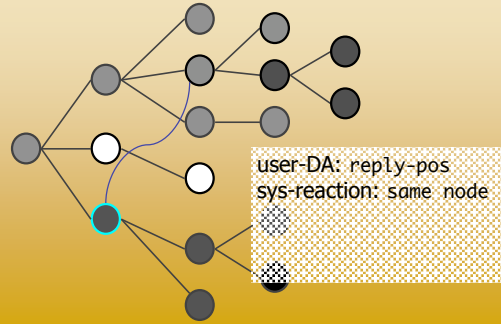

The weight-update mechanism

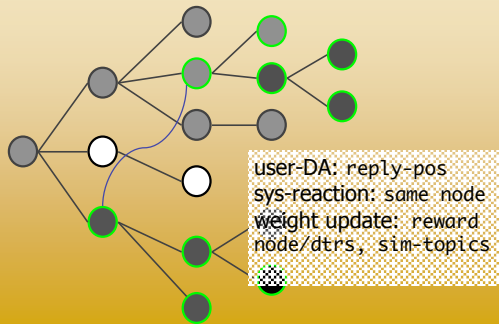

The weight-update mechanism

